

GRP storage cabinet: DMO-36

Dräger Marine & Offshore cabinets are designed for tough offshore conditions. Manufactured from durable GRP material, these cabinets are rated to IP56, certified by Lloyds. All cabinets are manufactured with stainless steel locks and hinges. The cabinets can be configured to suit different storage requirements.



Features

Room to store

- SCBA c/w cylinder and spare cylinder
- Emergency Escape Breathing Apparatus (2pcs)
- Survival suits (up to 2 pcs depending on type)
- Life jackets (up to 4 pcs depending on type)
- Chemical protection equipment
- Fall protection equipment / descent units (donut type)

Options

- Shelve
- Ventilation
- Flame retardant version
- Heaters (conventional / ATEX approved)
- Lettering

TECHNICAL SPECIFICATIONS

Dimensions	475 x 350 x 980 mm (LxBxH)
Aperture dimensions	475 x 310 x 830 mm (LxWxH)
Angle of door opening	90°
Weight	15 kgs
Material	GRP
Color	Safety Green RAL 6002 Firefighting Red RAL 3000 Safety Orange RAL 2009 Lifesaving White RAL 9010
IP rating	IP56
Door catch	Nylon
Door handle	SS 316
Hinges	SS 316
Seal	EPDM
Reinforcement	Core material
Lettering	White
Approvals	IP56 BS EN 60529:1992 Lloyds

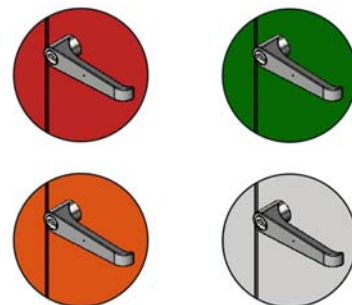

GRP storage cabinet: DMO-36
IP56 rated and Lloyds certified

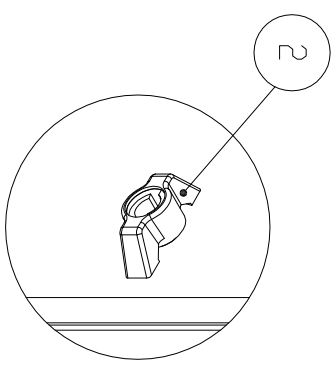
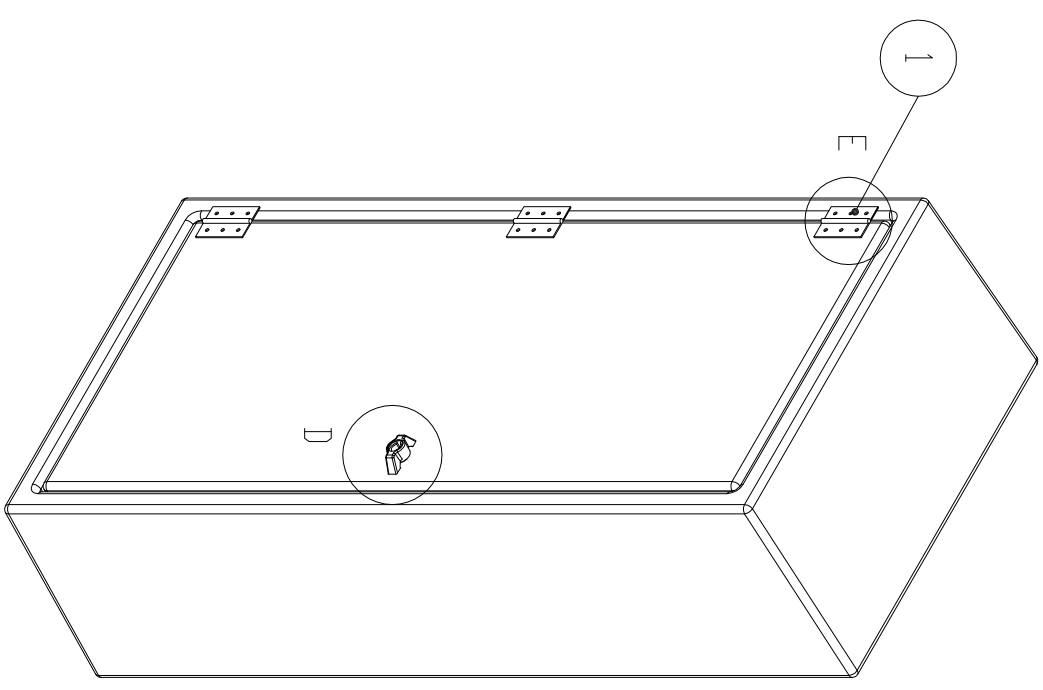
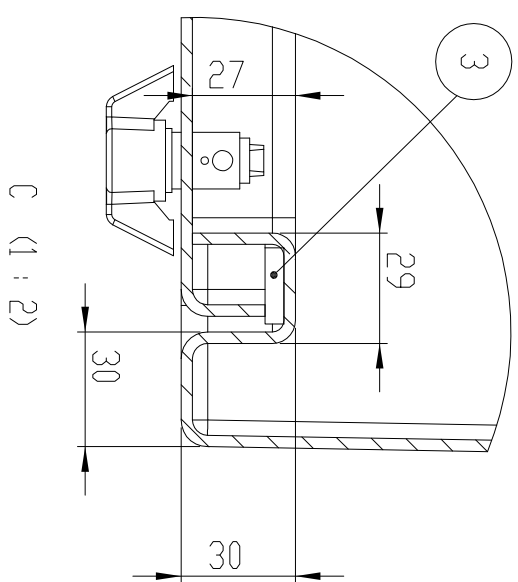
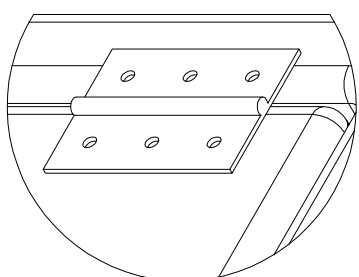
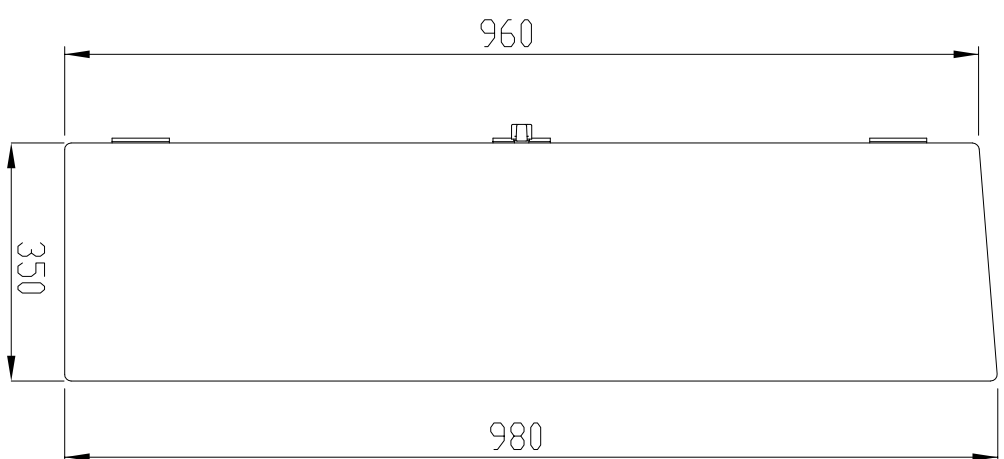
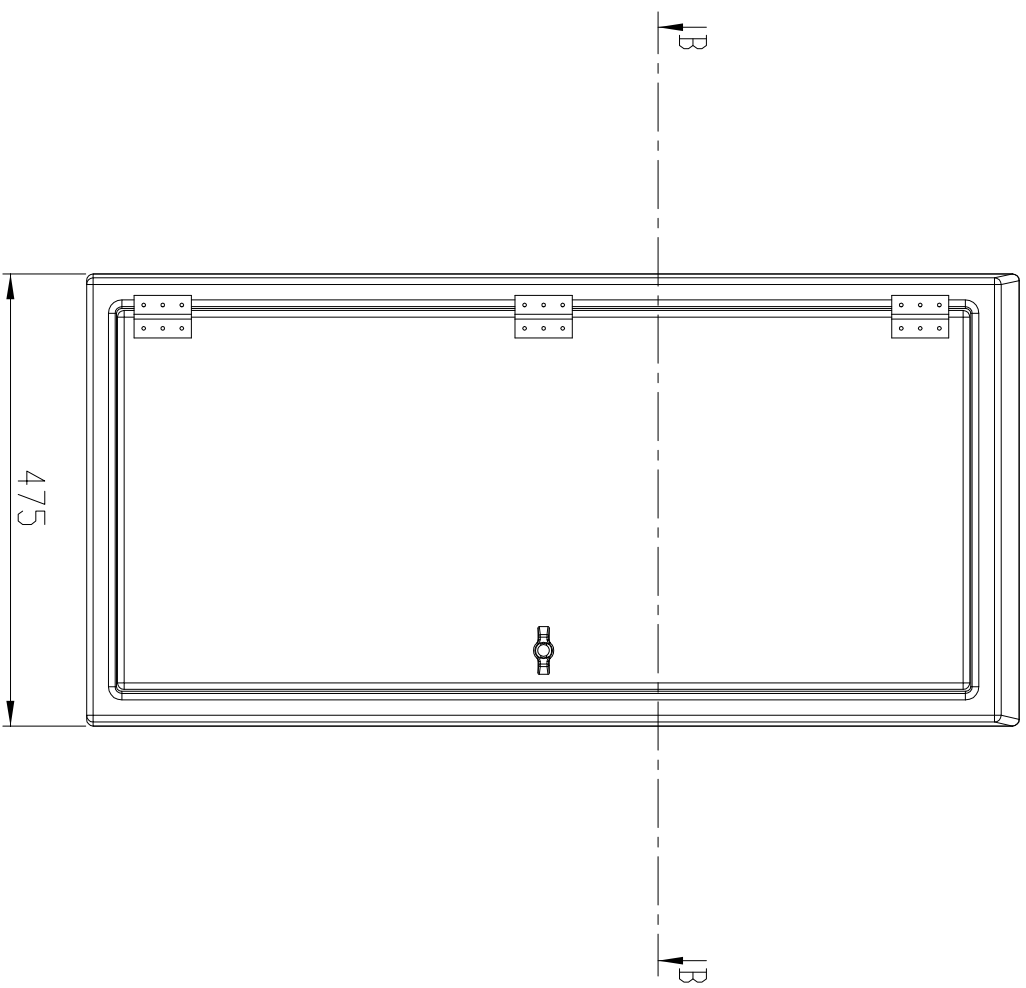
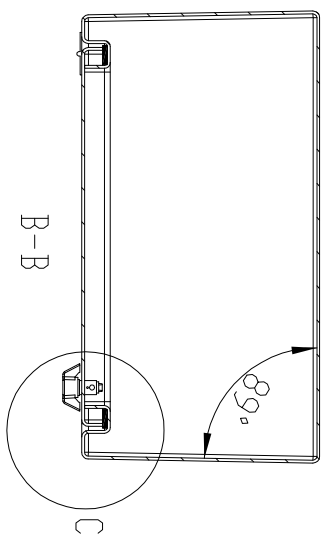

ITEM NO.	QTY.	PART NO.	DESCRIPTION
1	3		SS HINGE 75x75
2	1		SS Handle
3	1		EPDM SEAL

DMD-36

Name	TK	Weight	7Kg
Checked	*	Thickness	4mm
Date	16-12-2014	Colour RAL	TBA
Scale	1:18	Material	GRP
Belongs to	*		

Dräger

DMD-36

A3